

Read this instruction carefully. See hardware and furniture part list for guidance. Be sure all parts are complete, before you assemble. Place all wooden furniture parts on a clean and flat soft surface to prevent from being scratched. Follow the figure to start assembling.

CAUTIONS : 1. Do not FULLY - TIGHTEN the nut or nut bolt until all nut or bolt is ready assembled.
 2. Do not OVER - TIGHTEN the nut or bolt to avoid causing damages to the thread.
 3. Keep all hardware parts out of reach of children.

| PART LIST | | |
|-----------|-------------|-------|
| ITEM | DESCRIPTION | QTY |
| A | CHAIR | 1 PC |
| B | LEG FRONT | 2 PCS |
| C | LEG BACK | 2 PCS |

| HARDWARE LIST | | |
|---------------|---|-------|
| ITEM | DESCRIPTION | QTY |
| 1 | JCBB Bolt M8 x 45mm  | 8 PCS |
| 2 | M8 FLAT WASHER  | 8 PCS |
| 3 | M8 SPRING WASHER  | 8 PCS |
| 4 | M5 ALLEN KEY (BALL SHAPE)  | 1 PC |

NOTE : THE LIST AND QUANTITY SHOWN ARE FOR 1 UNIT ASSEMBLY.

STEP 1

1.1 Open the zip at the bottom of cushion seat and take out leg.

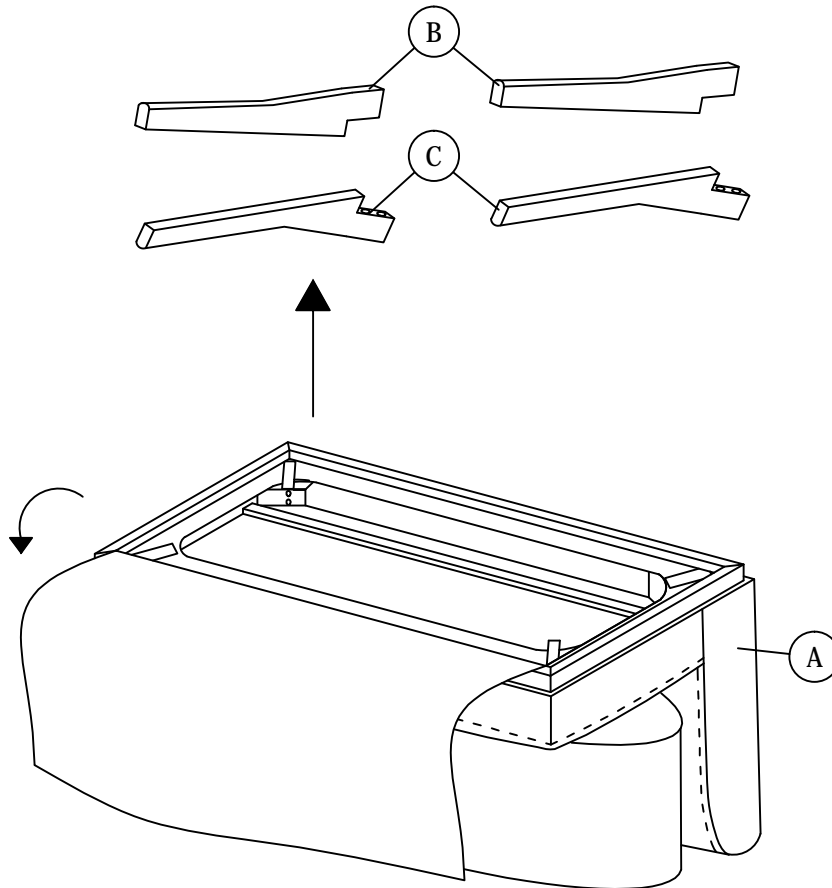

STEP 2

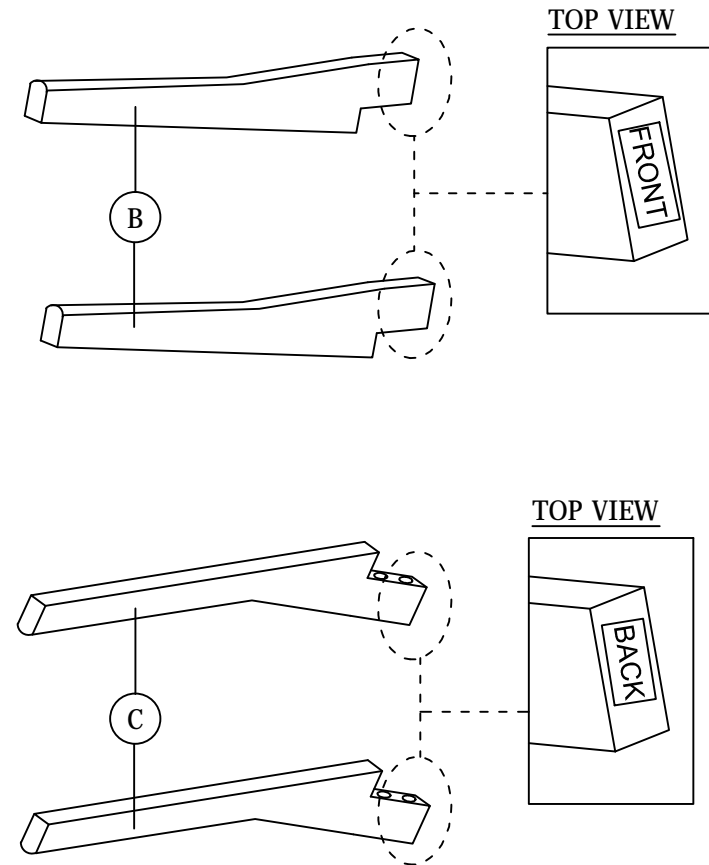

ASSEMBLY INSTRUCTIONS

STEP 3

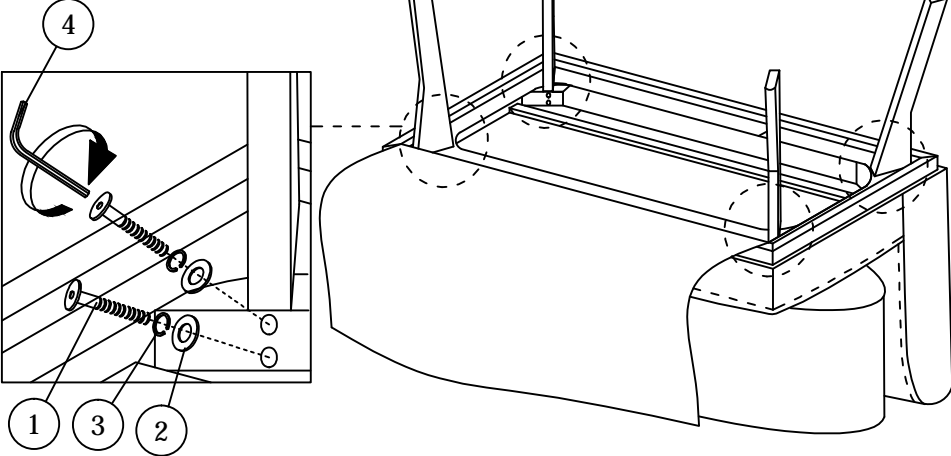
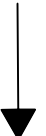
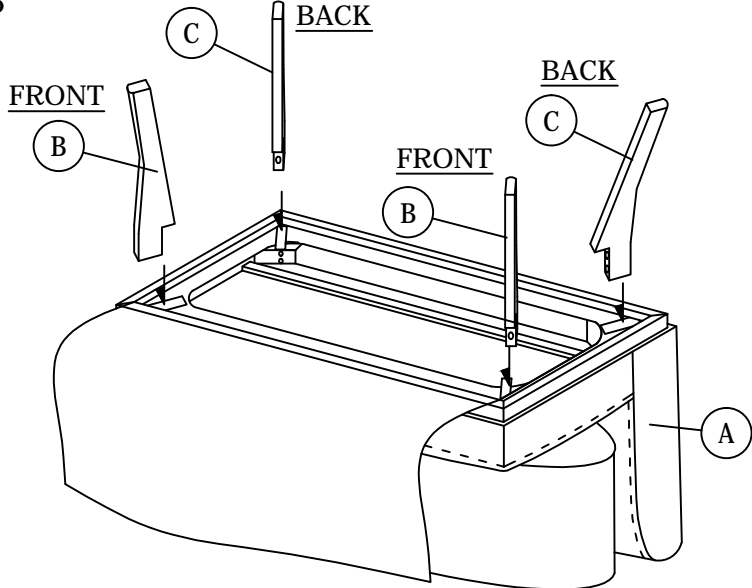

STEP 4

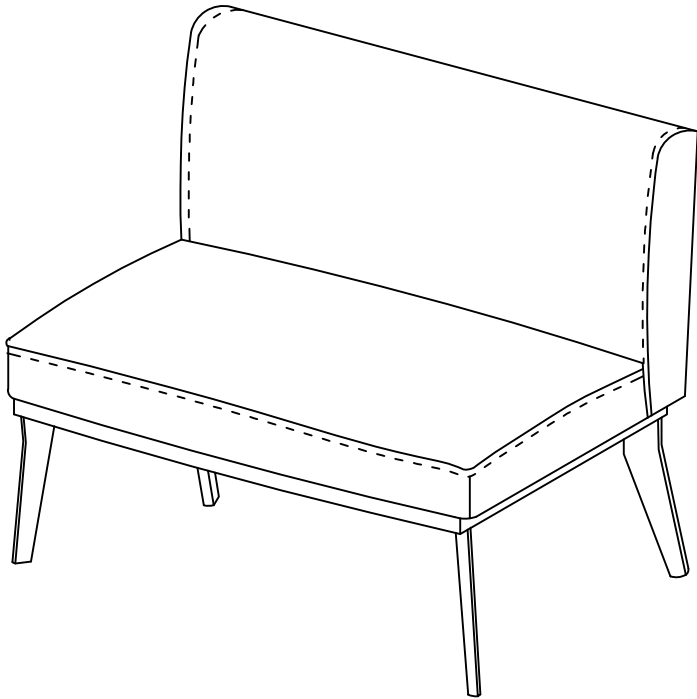

Read this instruction carefully. See hardware and furniture part list for guidance. Be sure all parts are complete, before you assemble. Place all wooden furniture parts on a clean and flat soft surface to prevent from being scratched. Follow the figure to start assembling.

CAUTIONS : 1. Do not FULLY - TIGHTEN the nut or nut bolt until all nut or bolt is ready assembled.
 2. Do not OVER - TIGHTEN the nut or bolt to avoid causing damages to the thread.
 3. Keep all hardware parts out of reach of children.

| PART LIST | | |
|-----------|-------------|-------|
| ITEM | DESCRIPTION | QTY |
| A | BENCH | 1 PC |
| B | LEG FRONT | 2 PCS |
| C | LEG BACK | 2 PCS |

| HARDWARE LIST | | |
|---------------|---|-------|
| ITEM | DESCRIPTION | QTY |
| 1 | JCBB Bolt M8 x 45mm  | 8 PCS |
| 2 | M8 FLAT WASHER  | 8 PCS |
| 3 | M8 SPRING WASHER  | 8 PCS |
| 4 | M5 ALLEN KEY (BALL SHAPE)  | 1 PC |

NOTE : THE LIST AND QUANTITY SHOWN ARE FOR 1 UNIT ASSEMBLY.

STEP 1

1.1 Open the zip at the bottom of cushion seat and take out leg.

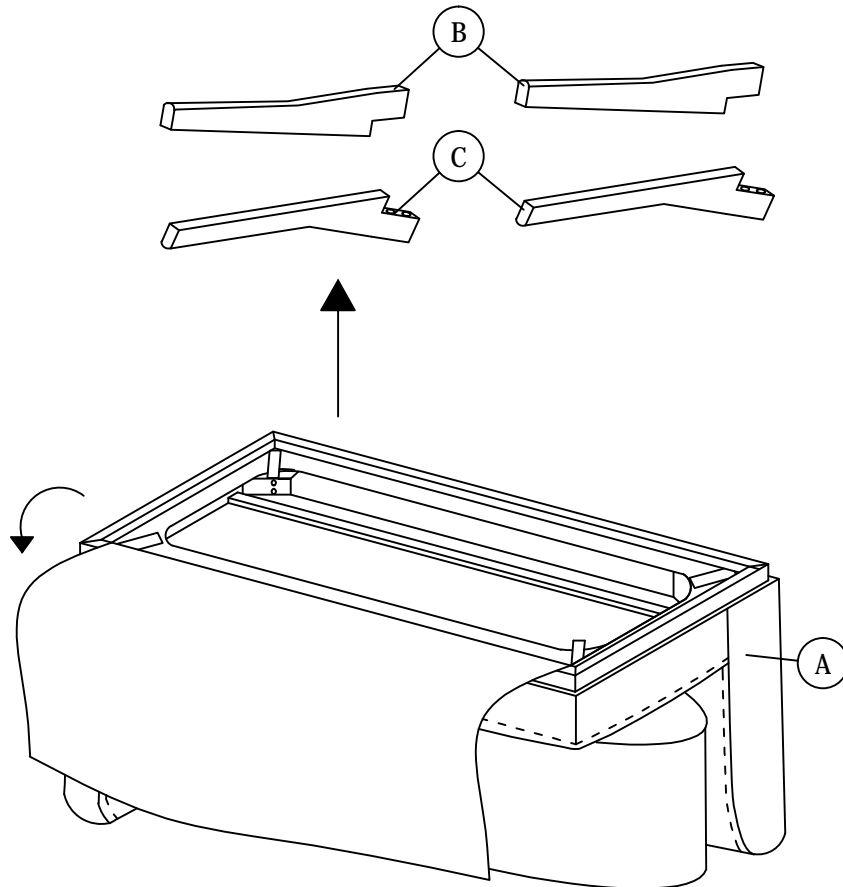

STEP 2

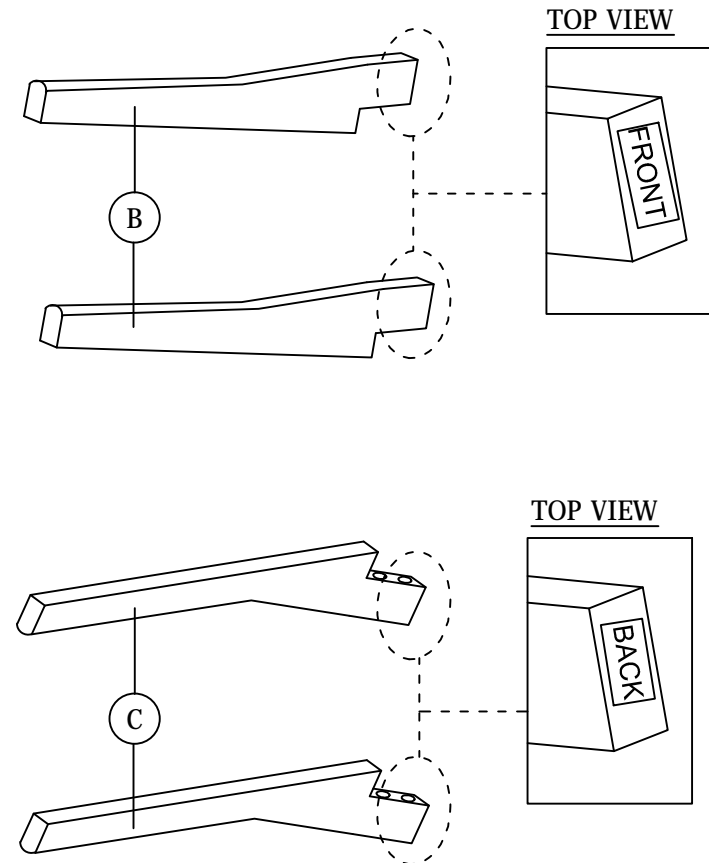

ASSEMBLY INSTRUCTIONS

STEP 3

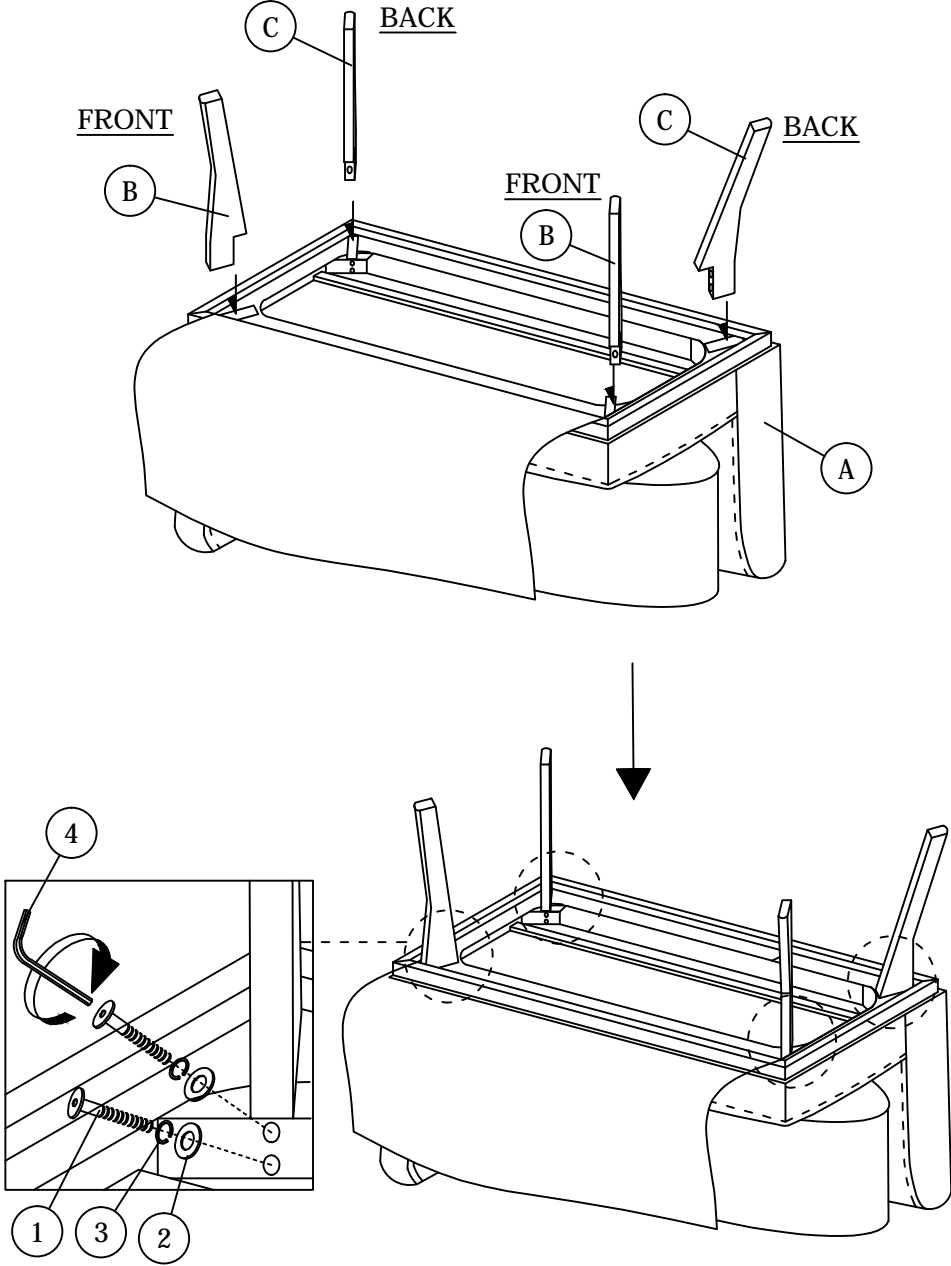

STEP 4

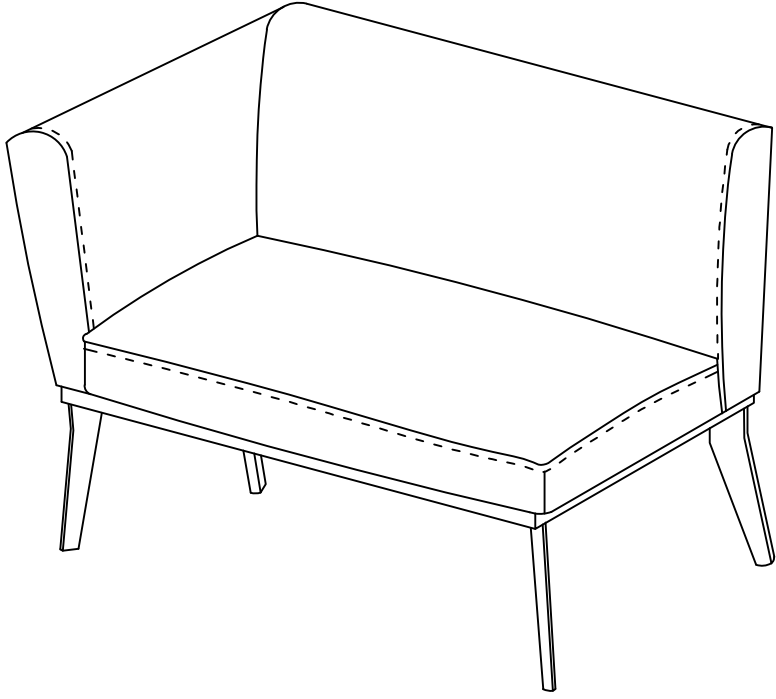

Read this instruction carefully. See hardware and furniture part list for guidance. Be sure all parts are complete, before you assemble. Place all wooden furniture parts on a clean and flat soft surface to prevent from being scratched. Follow the figure to start assembling.

CAUTIONS : 1. Do not FULLY - TIGHTEN the nut or nut bolt until all nut or bolt is ready assembled.
 2. Do not OVER - TIGHTEN the nut or bolt to avoid causing damages to the thread.
 3. Keep all hardware parts out of reach of children.

NOTE : THE LIST AND QUANTITY SHOWN ARE FOR 1 UNIT ASSEMBLY.

Tool needed : Screwdriver (not provider).

| PART LIST | | |
|-----------|-------------|-------|
| ITEM | DESCRIPTION | QTY |
| A | TABLE TOP | 1 PC |
| B | LEGS | 4 PCS |

| PART LIST | | |
|-----------|----------------------|-------|
| ITEM | DESCRIPTION | QTY |
| 1 | JCBC BOLT M6 x 35mm | 8 PCS |
| 2 | M6 SPRING WASHER | 8 PCS |
| 3 | WOOD SCREW M4 x 32mm | 8 PCS |
| 4 | M4 ALLEN KEY | 1 PC |

STEP 1

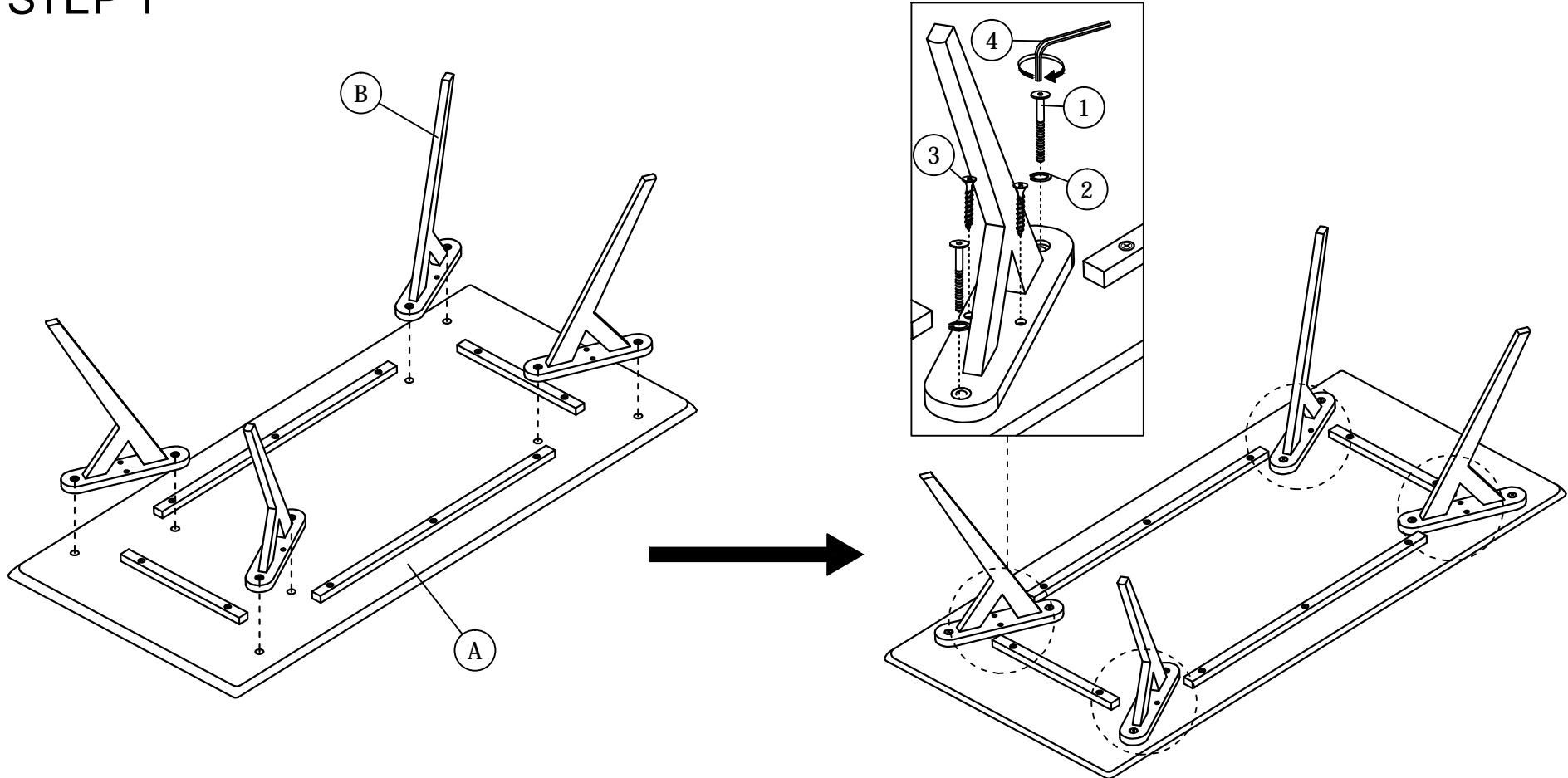

STEP 2

